



STEP INTO THE

# MODERN ERA

OF BREWING

## With the AccuBrew Fermentation Monitoring System

*From Gulf Photonics*



# Contents

02

Introduction

03

Why AccuBrew?

06

A Brief History of AccuBrew

08

Welcome To The Modern Era of Brewing

10

The Hardware

12

How It Works

13

The Online Portal

15

Interpreting the Data

24

Comparing the Data

27

The Future of AccuBrew

29

Gulf Photonics Quality Policy

30

AccuBrew Privacy Policy: Why A Subscription?

31

Thank You

# Introduction

**The goal of this document is to help brewers understand that AccuBrew is more than a monitor and early warning system!**

**We hope you take the following with you after reading.**

- AccuBrew is an analytical tool that provides brewers with the data required to stay competitive, react quickly to anomalies, and operate efficiently.
- Specific Gravity and Temperature alerts, and quick comparison of batches provides peace of mind.
- AccuBrew was designed with breweries and brewers in mind, from the robust sensor package to the intuitive user interface.
- Share data, communicate and collaborate securely and effectively with Team Messaging.
- Continuous improvement requires consistent results; consistent results require good communication, documentation, and data. AccuBrew delivers and protects that information and helps teams communicate effectively, and continuously improve.
- Build, preserve, and protect institutional knowledge using AccuBrew's BrewBook.

**We hope this inspires you to take the next step into the modern era of brewing with AccuBrew!**

# Why AccuBrew?

- **Peace of Mind.** First and foremost, AccuBrew provides peace of mind. AccuBrew monitors specific gravity, fermentation activity, clarity, and temperature 24/7. When suddenly gripped by the thought something is wrong, just check your phone, anytime, anywhere.
- **Detect, Act and Relax.** Currently, brewers test specific gravity once every 24 hours. AccuBrew gives brewers reliable SG test results every 15 minutes. That means 96 opportunities every day to detect problems and react quickly to out of range conditions.
- **Consistent Tests; Consistent Results.** Automatic, consistent results brewers can rely on 24/7 to protect their schedules and investment, compare batches, and improve their process and products.
- **Reduce Manual Testing by 80%.** AccuBrew automates all specific gravity tests between the post-boil original gravity test and the final gravity test, reducing manual SG testing by 80%. Just three AccuBrew sensors can save 64 hours per year at a typical brewery. Spend your time on other tasks or take a breather!



- **Save Money.** Every manual gravity test takes approximately 8 minutes, including prep, sample collection, testing, recording, and cleanup. We have done hundreds of them at AccuBrew. The labor associated with each test is roughly \$7.00 per test. At an average brewery, three AccuBrew sensors can save \$1000.00 annually, after the monthly subscription.
- **Communicate Effectively.** Communicate using the AccuBrew Team Messaging Board and set reminders to produce consistent results time after time.
- **Share Data.** AccuBrew data can be shared in real-time with collaborating breweries, or your customers if you are a contract brewer.
- **Preserve and Protect Institutional Knowledge.** Record what you do, why you do it, and how it evolves in AccuBrew's BrewBook. AccuBrew's secure record of every monitored batch, including brewer's notes and reminders, builds, preserves, and protects institutional knowledge, your most valuable intellectual property.
- **Fast ROI.** Three AccuBrew sensors can produce a positive ROI in just one year. The best part is each additional subscription is 60% off. The more sensors installed, the greater the savings, the better the ROI.

The savings and ROI realized by employing the AccuBrew Fermentation Monitoring System are independent of brewhouse capacity or fermentation vessel volume.

Whether a fermentation vessel is 1 bbl or 60 bbl the cycle time and number of SG tests per cycle, as well as the labor cost per test remain similar. This means even nano-breweries will save time and money with AccuBrew. In fact, as a percentage of net income, the smaller the brewery the more important the savings are to your bottom line.

## SAVINGS CALCULATOR



Calculator assumes \$25/hr total labor cost and 8 minutes per gravity test.

# A Brief History of AccuBrew

The AccuBrew Fermentation Monitoring System is a new product from Gulf Photonics, a division of Gulf Fiberoptics Group.

The AccuBrew story begins in 1996 with the creation of Gulf Fiberoptics. Through the late 1990s and 2000s, Gulf Fiberoptics grew to become an industry-leading manufacturer of optical fiber assemblies for the life science industry. Gulf Fiberoptics' diverse range of FDA registered medical devices for endoscopy, neurosurgery, and spinal surgery can be found in hospitals, surgical centers, and operating rooms in over forty countries. The foundation of the company is its energetic, dedicated staff, customer-focused culture, and comprehensive, certified quality system for compliance with global medical regulatory requirements.

In 2007, Gulf Photonics was created as a division of the Gulf Fiberoptics Group. The vision was to expand the capabilities and expertise Gulf Fiberoptics developed in the visible light spectrum to ultraviolet and near infrared wavelengths. In addition to the borosilicate glass fiber Gulf Fiberoptics manufactures for its medical devices,

Gulf Photonics designs and manufactures custom optical fiber patch cables, reflection probes, and other assemblies using a variety of multimode glass fibers with a wide selection of core diameters, coatings, buffers, and terminations.

As one of the few companies in North America operating in this space, Gulf Photonics has the expertise and experience to manufacture global products for the most demanding applications in medical, aerospace, defense, research, and now craft beer industries.



*Early AccuBrew prototype.*

**AccuBrew was conceived in 2017 when the Gulf Photonics team, looking for industries that could benefit from their unique skill set and knowledge, realized the brewing industry was still operating as it has for hundreds of years.**



Believing visible light could be used to bring breweries into the modern era, a proof-of-concept prototype was produced. Building and testing the prototype led the team to focus on the most critical and problematic step of the brewing process: fermentation.

The handmade prototype proved they could design a sensor to detect relative changes in sugar level and clarity using only visible light. And, more importantly, proved it was possible to produce a cost effective, maintenance free product to help breweries reduce manual testing and provide a permanent record of every batch.

During five years of brewing in the office and collaborating with talented local brewers, four iterations of the sensor package were produced, resulting in the robust stainless-steel sensor available today. Along with the development of a unique user interface, AccuBrew helps brewers keep eyes in the tank!

In 2023, after collecting tens of thousands of data points in-house, AccuBrew created an algorithm to provide brewers with consistent specific gravity measurements every 15 minutes.

Now, instead of one or two manual gravity tests a day, AccuBrew gives brewers 96 opportunities every day to react quickly to out-of-range conditions and turn tanks at the right time every time.

We hope our story provides some insight into the entrepreneurs and developers behind AccuBrew. They are a dedicated group of innovators always looking for new ways to apply their knowledge and experience.

**This is what we do!**  
**Join us in the journey!**



# Welcome to the Modern Era of Brewing

Customers are more demanding than ever. To succeed in this evolving environment, breweries need to evolve too. This doesn't mean chasing fads but working every day to improve each step of the process. Accubrew helps brewers leverage their knowledge and experience to work more efficiently, produce consistent products, and perfect the fermentation process.

At AccuBrew we have one goal to help brewers make great beer as consistently and efficiently as possible! To that end the AccuBrew system was designed to give brewers the information they need to monitor and compare batches to stay competitive.

**AccuBrew believes in, and practices the philosophy of continuous improvement.**



Continuous improvement is a four-step process. Repeating these four steps, and being open to change, will incrementally improve any process. Improvement requires communication and data. This is where AccuBrew comes in!



## PLAN

Identify areas to improve, make a plan, and organize staff.



## DO

Follow the plan and collect the data.



## STUDY

Study the data.



## ACT

Act on the results.

# The AccuBrew system is an analytical tool to help brewers follow the plan and communicate by setting reminders, gathering feedback through Brewer's Notes, and collecting and preserving the data used to evaluate and compare the results of incremental process adjustments.

The system consists of a sensor package and online portal. Every 15 minutes the visible light sensor detects changes in specific gravity, temperature, total sugars, and the particulates in the fermentation vessel. This information is transmitted to the cloud and shared through an online portal across all of your devices.

The online portal combines and securely stores fermentation sensor data and Brewer's Notes to create a historical

record that allows brewers to document and compare batches to better understand and incrementally refine the fermentation process.

In a barley husk: AccuBrew helps brewers monitor, confirm, compare, and improve.

**Let's explore the AccuBrew Fermentation Monitoring system in more detail!**



# The Hardware

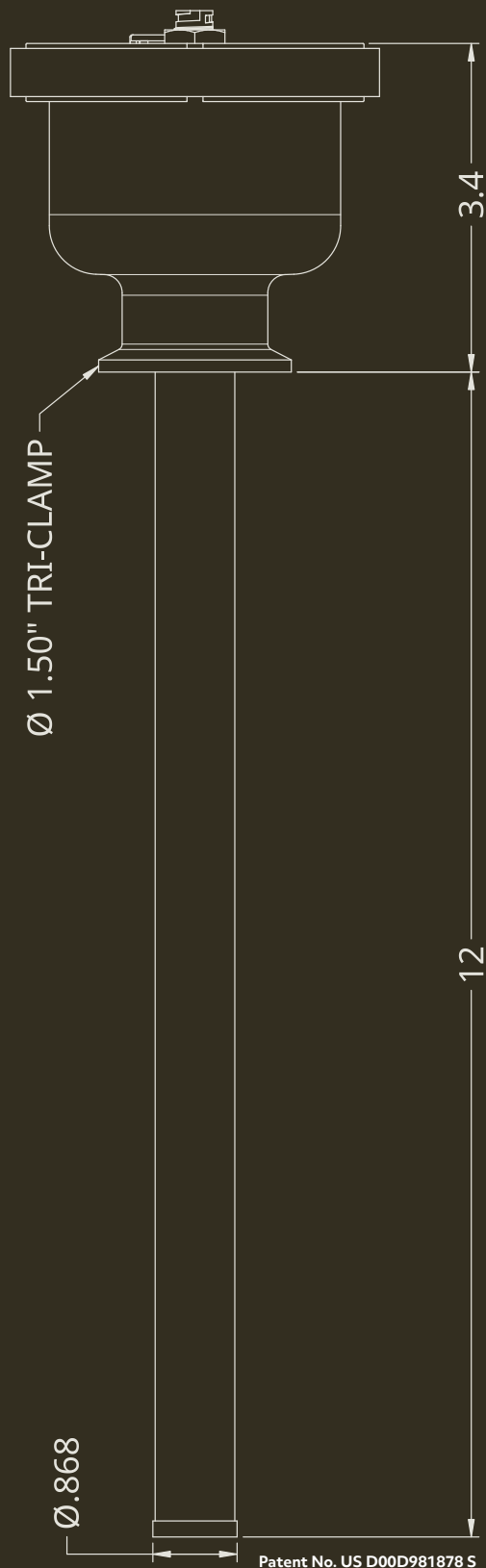

The AccuBrew sensor is a visible light, reflection/backscatter device. The AccuBrew sensor package was designed in-house using proven off-the-shelf components and built tough to survive production breweries.

The AccuBrew sensor begins with a robust maintenance free stainless-steel, CIP ready housing. The housing contains all the electronics, comprising the sensor PCB, the control and communication PCB, the temperature sensor, and backup battery.

The IoT sensor mounts through a standard 1.5" TC port. Thanks to the length of the sensor, it can be installed through a sanitary T-fitting into tanks without a spare port. In this way the sensor and sample valve are mounted to a single port.

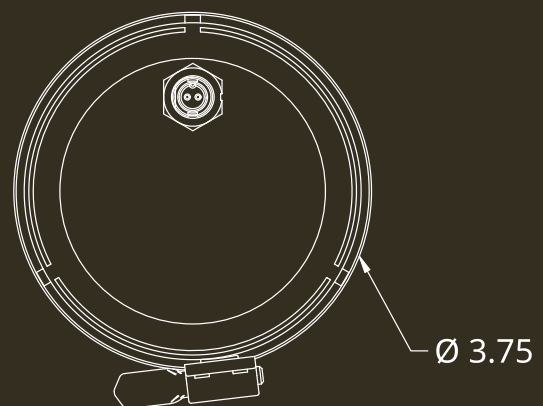

**The AccuBrew sensor's faceplate, machined from 6.35 mm thick vapor polished acrylic, is sealed with a standard 3-inch gasket. The faceplate contains two membrane switches and the IP69K power connector.**



The sensor PCB views the inside of the fermentation vessel through a 4.5 mm thick optically flat borosilicate window. The window will not leak, even if cracked. The sensor PCB includes a full spectrum visible light LED and multiple detectors to capture the light reflected back to the sensor by the sugars and particulates in the fluid. A vibratory motor prevents particles from adhering to the detector window.



The sensor package also includes a highly accurate CMOS digital temperature sensor. The temperature sensor is accurate to  $\pm 0.1$  degrees Celsius max at a 1k sample rate. As a result of the sensor's accuracy and position deeper into the vessel, AccuBrew generally recommends trusting the AccuBrew system when there are differences between the output of the AccuBrew sensor and the glycol system temperature controller.



The AccuBrew sensor is powered by a low voltage (120VAC 60 Hz) DC adapter connected to the IP69K rated fitting by a 10-meter food grade cord. This ensures the sensor can operate in the harsh, wet environment of a brewery. AccuBrew also provides a low power adapter for hardwired installations.



The main board includes the processor, a 2.4 GHz Wi-Fi transmitter/receiver, an 1,800 mAh backup battery, and the onboard memory. In the event of a power failure or an interruption of the Wi-Fi signal, the backup battery and onboard memory allow the sensor to continue testing and recording sensor data for 6-8 hours. Once the internet is restored the stored data is automatically uploaded to the cloud.

# How It Works

AccuBrew uses visible light to measure the wavelengths reflected – or absorbed – within a liquid. By tracking the absence or return of specific colors, AccuBrew builds a picture of what is and isn't in the tank. By taking constant measurements AccuBrew monitors changes over time as the fermentation process advances and flocculation occurs. The low intensity, visible light AccuBrew sensor does not emit UV light and will not trigger photo-oxidation.

The AccuBrew sensor is a virtually zero maintenance measurement device that never needs calibrating. To operate under a variety of conditions the sensor performs an initial warmup, cleaning, and auto-ranging sequence before every set of measurements. After starting a run, measurements are automatically taken every 15 minutes until the run is stopped by the brewer.

Prior to each measurement cycle, a vibratory motor is given three 200 millisecond pulses to clear the detector window of particulates and the visible wavelength LED is warmed up for 60 seconds. After the detector window is cleared and the LED is warmed up, the auto-ranging sequence occurs.

After auto-ranging, the LED is energized for another 60 seconds. During this time, the sensor takes 100 visible light measurements and 100 temperature readings. These measurements are averaged, and the resulting values are used to calculate the SG, Fermentation Activity, Clarity, and Temperature Profile data points. The data is temporarily stored in the onboard memory.

The raw data produced by the sensor package is uploaded to the cloud over a 2.4 GHz Wi-Fi connection. To protect the information, all data is retained in the sensor's onboard memory until confirmation is received from the cloud that the data is securely stored on the server.

Once the data is safely stored online, the specific gravity value, the fermentation activity, clarity, and temperature profile values are made available to share 24/7, across devices, with staff, collaborating brewers, and contract brewery customers.

# The Online Portal

Once the hardware was on its way, the hard part began, creating the software to power the developers' vision and the user interface to empower brewers.

The online portal is the brewer's connection to the AccuBrew sensor and data. The portal is accessed using our mobile or web apps. Sensors are claimed using the mobile app. Graphs are viewed and batches compared using a web browser.

## Through the Online Portal, Brewers Can:

- ✓ Claim and Name Sensors
- ✓ Start and Stop Runs
- ✓ Configure Gravity and Temperature Alerts
- ✓ Monitor the Current Batch
- ✓ Compare and Share Batches
- ✓ Set Custom Reminders
- ✓ Enter Brewer's Notes
- ✓ Access the Team Message Board
- ✓ View the Calendar

An important feature of the AccuBrew system is the BrewBook. Brewers enter Brewer's Notes into the Brew Book. Detailed notes add context to the historical record. Notes are used to record when, what, and how much was added during fermentation, the reason for a temperature setpoint change or deviation, test results, or any note of a significant event for future reference. The more notes brewers add to the BrewBook the more valuable the record becomes.

Brewers can also set custom reminders. By setting custom reminders, head brewers ensure the brew team stays informed and every step of the fermentation process is done at the right time, every time. Knowing when something was done and confirming it was done helps ensure consistency.

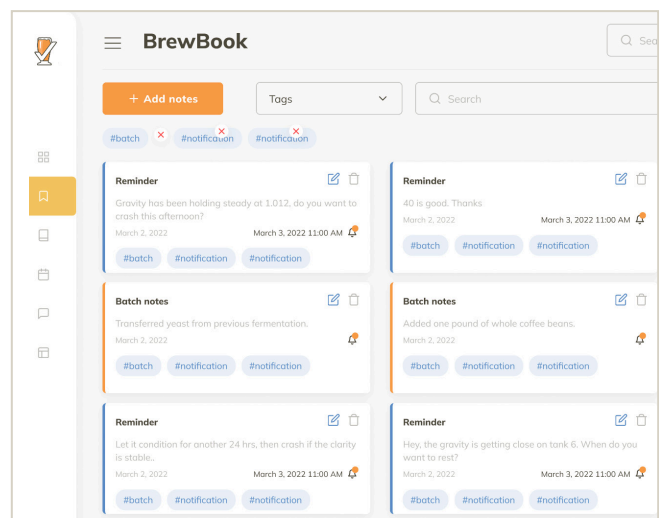

Our system includes a Team Message Board. Integrated messaging helps team members communicate effectively. The message board keeps messages in one place creating an archive of all communication. The Team Message Board also protects employee privacy and reduces risk by not requiring employees to share personal information to communicate with management and among themselves. Additionally, by setting reminders and entering messages after tasks are completed, a communication loop is created that acts as an oversight tool.

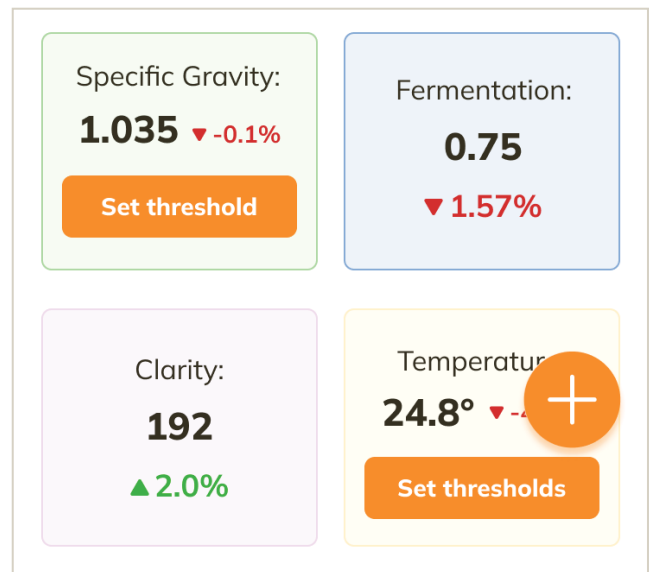
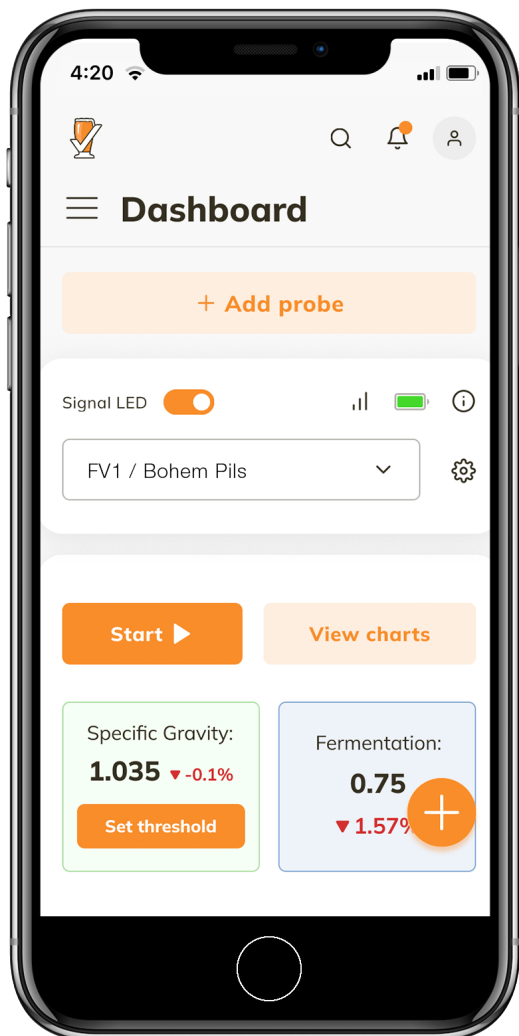

Specific gravity and temperature alerts are batch and schedule saving features of the AccuBrew system. Brewers set over/under specific gravity and temperature alert values. AccuBrew then monitors specific gravity and temperature 24/7. If either value falls outside of the user set thresholds, a notification is sent to brewers' phones allowing them to take immediate action to resolve the problem. Just one AccuBrew sensor helps protect every tank on the same glycol system in the event of a power outage or glycol system failure.

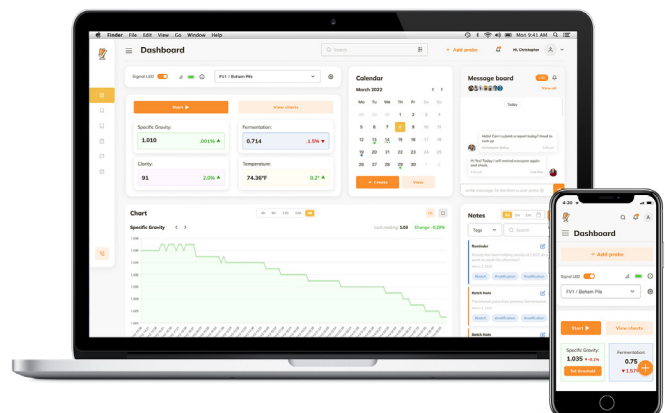

# Interpreting the Data



**Customers compare every batch.**

**AccuBrew helps brewers compare batches with precision.**

AccuBrew's goal is to provide brewers the information to achieve and maintain the consistency required to continuously improve their products. Interpreting the data and comparing one batch against another is critical to this process. First, let's learn how to interpret the data.

AccuBrew displays four graphs or profiles to interpret and compare:

**Specific Gravity (SG), Fermentation Activity, Clarity, and Temperature.**



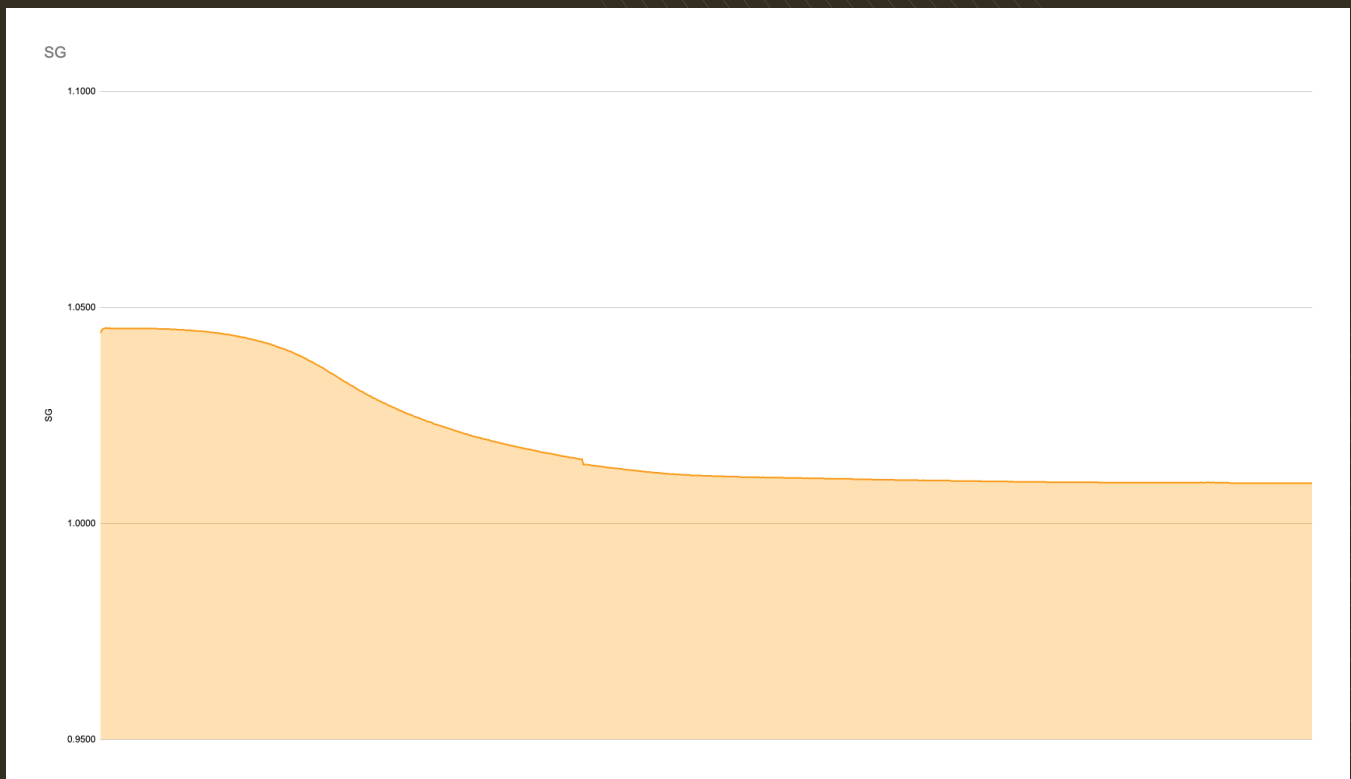

## Specific Gravity

The Specific Gravity Profile is a visible record of the SG measurements taken during fermentation. As fermentation progresses, the SG profile trends downward over time. Brewers will use the SG profile along with the Fermentation Activity and Clarity profiles to confirm fermentation is progressing as expected, or is in danger of stalling, and to decide when to initiate rests or make additions. The SG profile will appear relatively smooth.

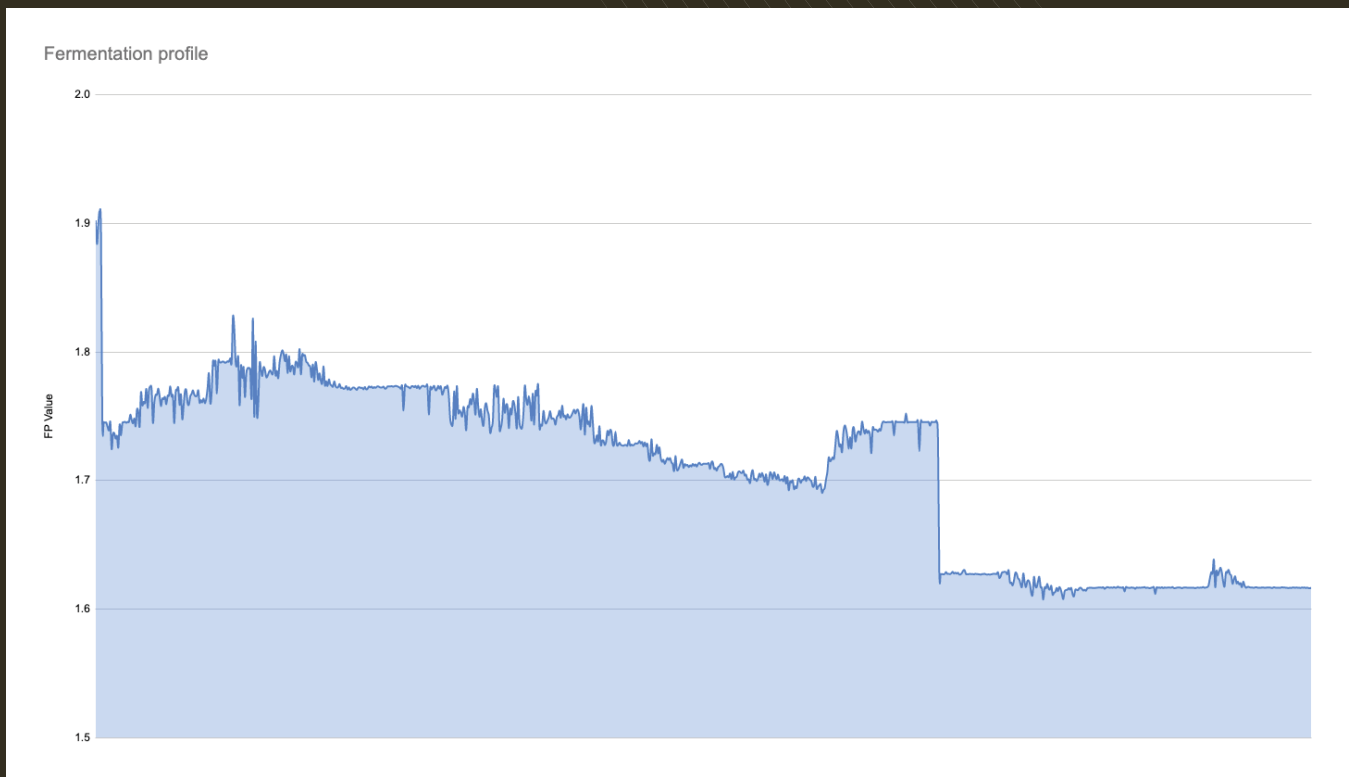

## Fermentation Activity

The Fermentation Activity Profile is a relative record of the total sugars in solution, both fermentable and non-fermentable. Sugars absorb blue light. As fermentation proceeds, the amount of blue light returning to the sensor increases as the amount of all sugars in the tank decreases and less blue light is absorbed. The Fermentation Activity Profile trends downward over time as fermentation progresses. The Fermentation Activity Profile will appear much more dynamic than the SG Profile.

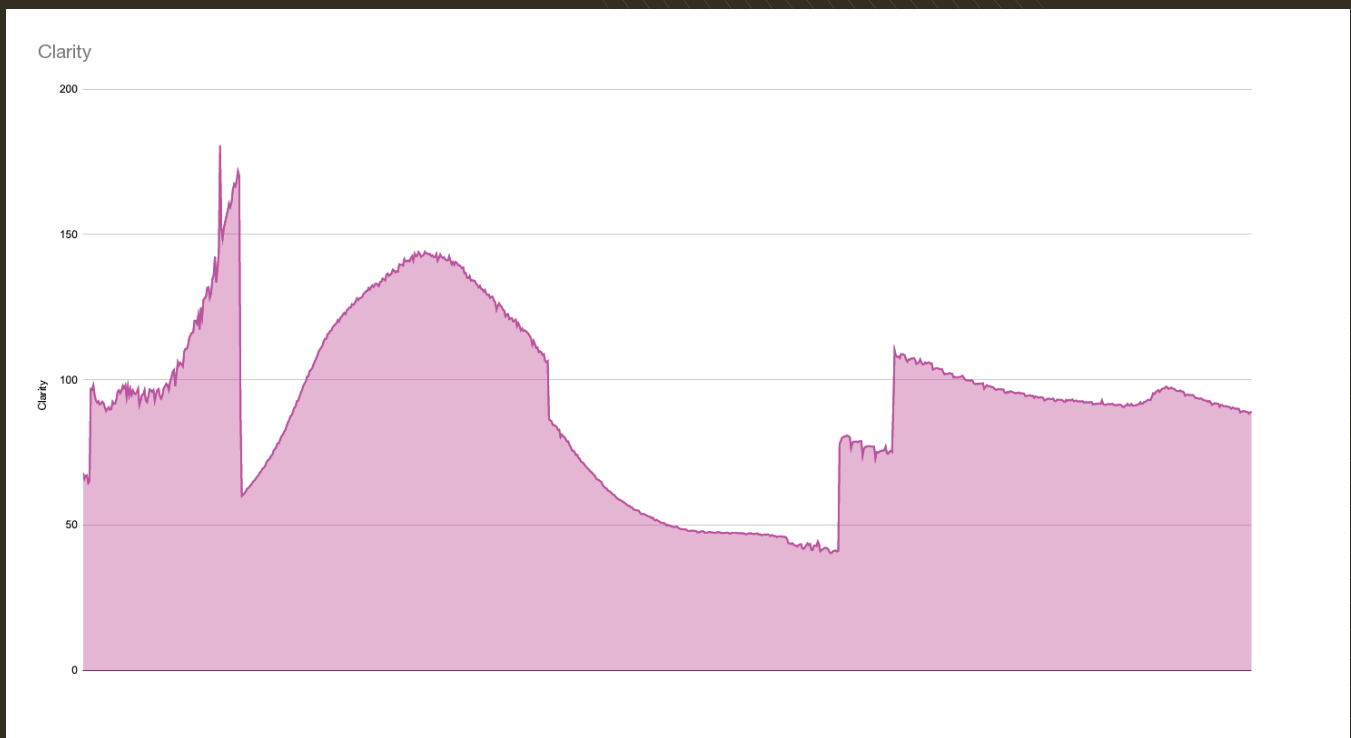

## Clarity

AccuBrew's unique Clarity Profile is a relative record of the number of particles in front of the sensor. Peaks indicate higher concentrations of particulates in front of the detector window. Valleys indicate lower concentrations as yeast, hop particles, and other solids introduced by the addition of cocoa nibs, etc. drop out of suspension and clarity improves. Striations in the wort may also create peaks and valleys as they pass in front of the sensor. The Clarity Profile trends down over time as particles drop out of suspension. The Clarity Profile will also appear more dynamic than the SG Profile.

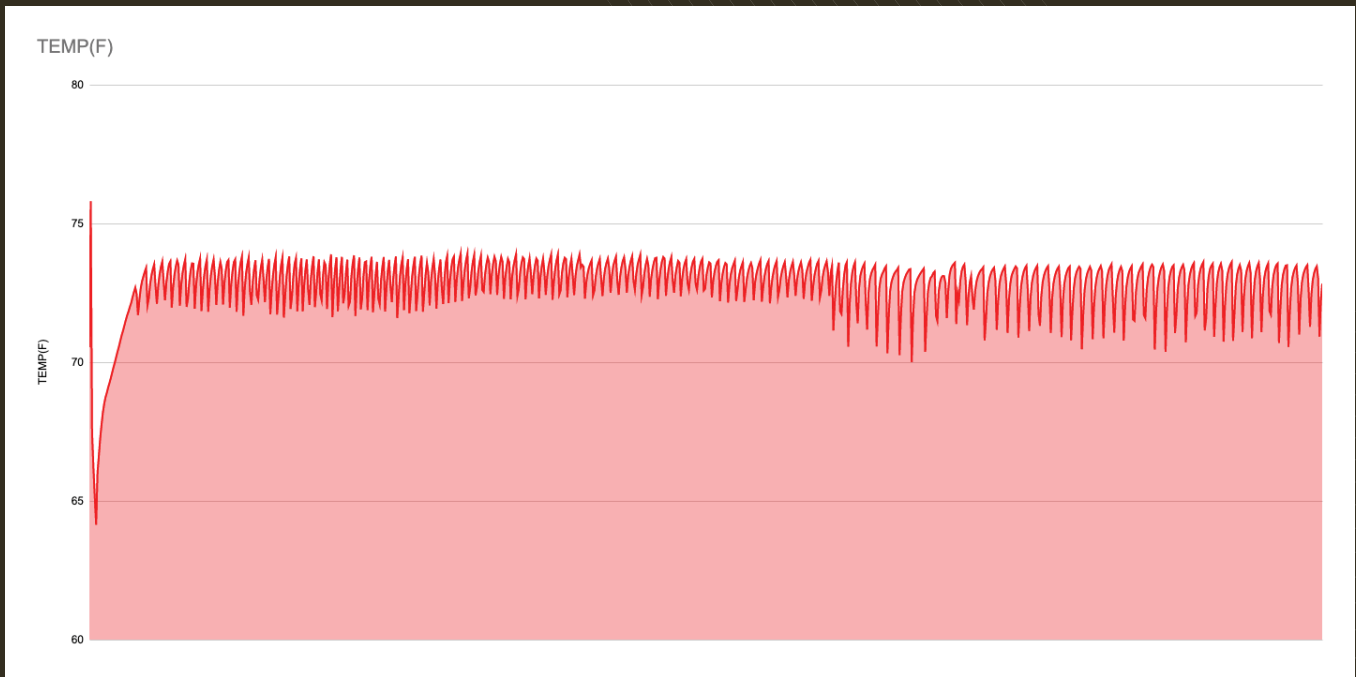

## Temperature

The Temperature Profile is an absolute record of the temperature recorded by the sensor. After the temperature stabilizes, the temperature graph will take on a sawtooth pattern as it records the normal temperature fluctuations in the tank as the glycol system cycles on and off.

In addition to the four graphs, AccuBrew displays at-a-glance percent of change values for the specific gravity, fermentation activity, and clarity profiles, and the degrees of change of the temperature profile. The at-a-glance values reflect the changes between the most recent measurements and measurements taken four hours earlier. The at-a-glance values are the quickest way for brewers to confirm fermentation is progressing as expected.

The AccuBrew sensor is like a camera taking snapshots of everything passing in front of its lens. When the sensor's visible light LED is energized, a small dome shaped area of the wort is illuminated centered on the LED. The sensor interprets light reflected back to the sensor from the area within the dome of light to produce the values used to calculate Specific Gravity and the data points for the Fermentation Activity and Clarity Profiles.

An important consideration when interpreting the data is changes in the Fermentation Activity Profile are better understood considering corresponding changes in the Clarity Profile. The two graphs work hand in hand to reveal changes in overall chemistry. Additionally, transient data points are not indicators of a problem, anomalies may occur. Wait for another data point to be displayed and follow the trendline.

In the first 12-24 hours after a run is started, brewers may notice seemingly random data points. This is the effect produced by the chaotic nature of the fluid after filling the fermentation vessel, rapidly cooling the wort, and pitching the yeast.

- Initially, the temperature may drop well below the glycol system setpoint as rapidly cooled wort cascades down the vessel's walls. The most important thing to remember when using a temperature sensor is temperature sensors only measure their own temperature. If the sensor's location is in the cone of the fermentation vessel, as the rapidly chilled wort sinks it displaces warmer fluid and pools in the cone. The sensor will reflect this condition. This usually stabilizes within the first hour.
- Clarity will fluctuate as particulates are carried past the detector window. This generally stabilizes within the first twenty-four hours. However, clarity is always subject to large particles passing in front of the sensor window.
- The Specific Gravity and Fermentation Activity profiles will also fluctuate as the amount of blue light returning to the sensor is affected by the clarity and turbulence of the fluid. These too will stabilize in the first 24 hours.

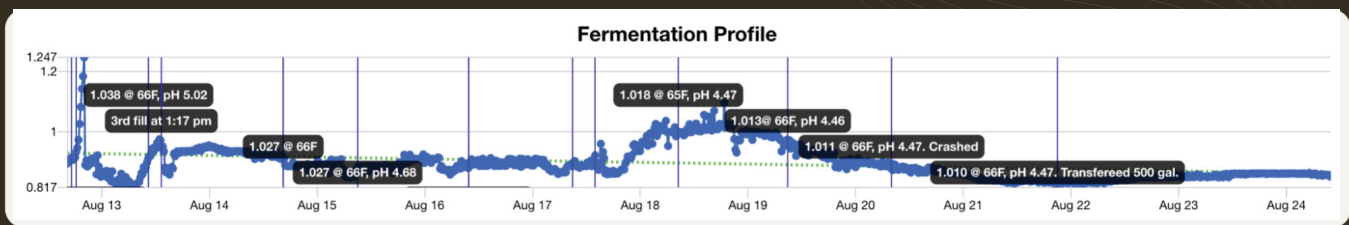

Notes of test results and significant events add important context to the historical record. The more information entered the more valuable the record. The notes recording SG and pH test results were entered by the brewer.

After the yeast is pitched and the temperature stabilizes, brewers will notice the following:

- The temperature graph will take on a sawtooth pattern centered around the setpoint as the glycol system cycles on and off. Brewers can use this pattern to set the over/under values for the temperature alert.
- Clarity measurements will begin to become less random as turbulence decreases and particulates stratify.
- Clarity will initially decrease as the yeast goes through its growth phase. This portion of the Clarity Profile is a good indicator of yeast health when compared to earlier batches.
- The Fermentation Profile will settle at its peak.
- Specific Gravity will also settle at its peak value.

In the first week, as the yeast enters the anaerobic phase and fermentation begins in earnest, the graphs will reflect the following characteristics:

- While sensor measurements will always be subject to large particles drifting past the sensor, the graphs will generally become smoother, exhibiting far fewer transient spikes.
- Temperature should not change by more than a few degrees unless a brewer has adjusted the setpoint or there was a system failure. If there was a system failure and brewers did not receive a notification, the temperature alert over/under values should be adjusted.
- The Clarity Profile, having reached its initial peak, will begin to trend downward as particulates stratify or drop out of suspension. If the Clarity Profile begins to trend upward unexpectedly, this could indicate the yeast is flocculating prematurely and fermentation is in danger of stalling.

- The Fermentation Activity Profile will continue to trend downward after the yeast enters the anaerobic phase and sugars are converted into alcohol. If during this phase the temperature is increased, the Fermentation Activity Profile will trend upward and possibly appear to fluctuate as yeast activity increases causing changes in clarity.
- The Specific Gravity value will trend downwards, indicating fermentation is progressing. The SG Profile will generally appear much more stable, smooth, in comparison to the other more dynamic profiles. If Specific gravity stabilizes unexpectedly, this could indicate fermentation is stalling.
- If the Fermentation Activity and Clarity profiles cease indicating change and the SG value is above the final gravity target value, before the expected end of fermentation, fermentation has stalled, and brewers should consider taking immediate action to restart fermentation.
- During this time, the Clarity Profile will resemble a series of peaks and valleys as yeast continues to stratify and flocculate, especially after the introduction of a fining agent.
- The addition of fining agents can create distinct striations in the vessel as flocculating yeast, proteins, and polyphenols bind together in layers before dropping out of suspension. However, the Clarity Profile will continue to reflect a downward trend, meaning clarity is improving.
- Random spikes may still appear as large particles pass in front of the sensor, but these spikes should become less frequent.
- The Fermentation Activity Profile will continue its downward trend, albeit at a slower rate, indicating fermentation is progressing and possibly nearing completion.

**In the second week, with fermentation nearing completion, brewers will notice the following:**

- The Temperature Profile should be one long, uninterrupted sawtooth pattern, unless the temperature setpoint was intentionally changed, or a decision was made to cold crash.
- If fermentation has progressed normally, the Specific Gravity value will settle at or near the final gravity target value, exhibiting very small changes over longer periods.

Once the decision is made to cold crash, the graphs will reflect the following:

- **The Temperature Profile** will drop precipitously reflecting the change in setpoint. Once the temperature stabilizes around the new setpoint the sawtooth pattern will reappear. After crashing, the temperature alert over/under values should be adjusted to protect the batch during this step of the process.
- **The Clarity Profile** will initially reflect a decrease in clarity, a higher level on the graph, as flocculation increases and clumps of yeast drop out of suspension. Clarity may also temporarily decrease as yeast suspended above the sensor flocculates and stratifies. Eventually the Clarity Profile will stabilize letting brewers know most particulates that can drop out of suspension have done so.
- **The Fermentation Profile** will flatten considerably after the batch is cold crashed, though it will continue to reflect a small rate of change in total sugars as long as viable yeast exists. As before, it is important to remember the Fermentation Profile is always interpreted with respect to the Clarity Profile.
- **Specific Gravity** may continue to indicate small changes over longer periods before stabilizing at or near the predicted final gravity value as fermentation slows and ends.

Yeast is not an ingredient; yeast cells are collaborators. Brewers who understand and respect this difference win customers and awards.

The final gravity target value and fermentation time are calculated estimates. Target gravity and time are not hard stops if fermentation remains active. This leads to under-attenuated products. It is important to allow fermentation to complete in its own time. The brewer's job is to create and maintain a healthy environment in which yeast cells work efficiently.

When a batch misses its final gravity target, takes longer than expected, or ends prematurely, the AccuBrew data can be used to compare succeeding batches to the problem batch. Using the AccuBrew Fermentation Activity and Clarity Profiles, along with SG data, brewers can monitor and evaluate recipes and process changes to produce properly attenuated beers of the desired gravity in a reasonable time.



# Comparing the Data

Customers compare every-batch, AccuBrew helps brewers compare every batch from beginning to end.

Any time is a good time to compare fermentation data. Comparing the current batch against an historical batch helps confirm fermentation is progressing as expected and any changes to the process are producing the desired results. It is important to restate the value of Brewer's Notes. Detailed notes add invaluable context to the historical record.

As important as specific gravity is to brewing, you will notice that when comparing data, it is equally important to compare the Fermentation Activity and Clarity Profiles. Comparing these two profiles, along with the specific gravity data and Brewer's Notes give brewers a fuller understanding of the fermentation process.

The first step is to identify a gold standard batch. A gold standard batch is a batch that ferments efficiently and produces the sensory and test results expected from the recipe and for the style. Each succeeding batch is then compared against this batch until a new reference batch is created.

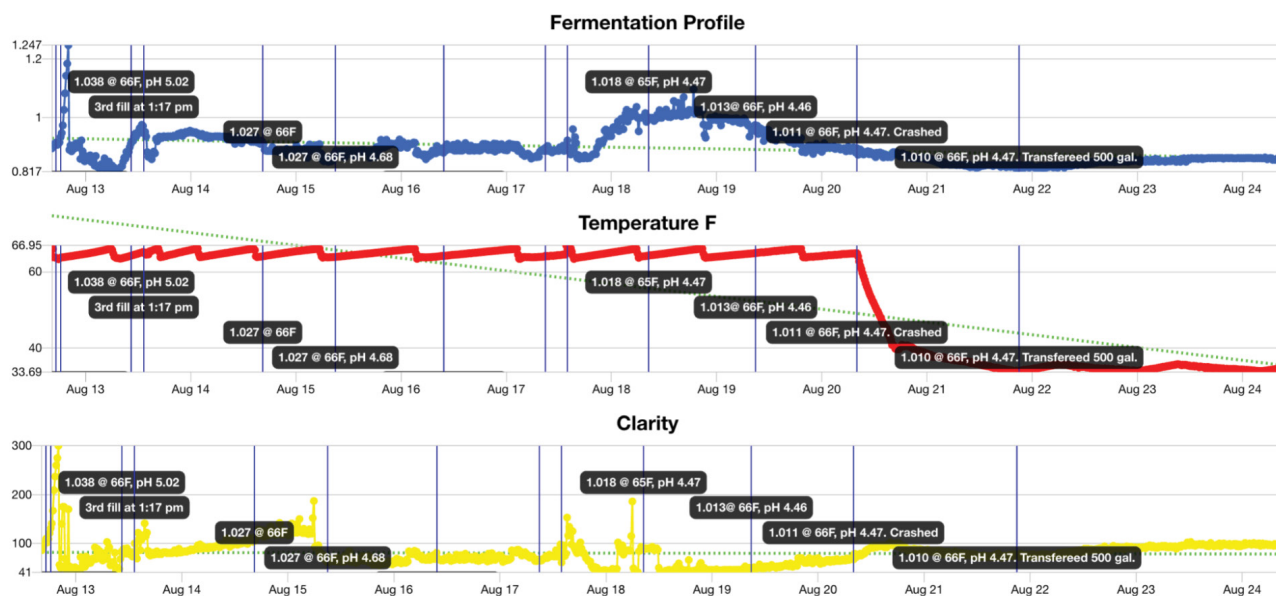

AccuBrew records relative changes over time. This image illustrates the relationships between the three profiles and the value of the AccuBrew Brew Book. Notes, added by the brewer, connect the three profiles.

AccuBrew records changes over time creating Specific Gravity, Fermentation Activity, Clarity, and Temperature profiles. The vertical line on the left, the y-axis, is the amplitude and the horizontal line across the bottom, the x-axis, is time. The batch profiles are compared to confirm similar peaks and valleys occur at similar times. Comparing these milestones helps confirm consistency.

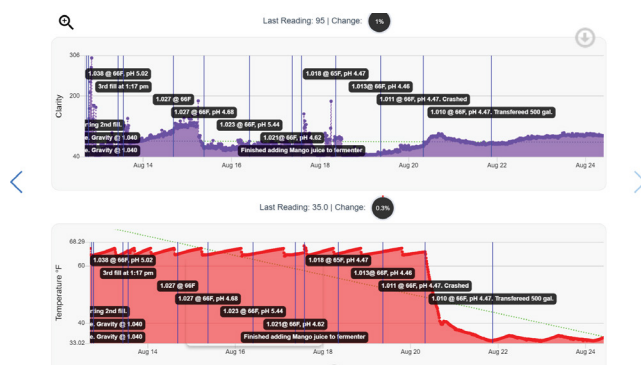

*The high resolution Temperature Profile takes on a sawtooth pattern as the glycol temperature controller cycles on and off. Notes, added by the brewer, are securely stored.*

It is important to always compare all four profiles, especially the Fermentation Activity and Clarity Profiles. As stated earlier, the Fermentation Activity Profile is influenced by the Clarity Profile and changes in the Fermentation Activity Profile are better understood considering corresponding changes in the Clarity Profile.

Due to the relative nature of the Fermentation Activity and Clarity Profiles, the scale of the vertical y-axes may shift from one batch to another. However, the overall differences between the peaks and

valleys of each batch should present similar profiles. We are not comparing scale; we are comparing shapes. When the Fermentation Activity and Clarity profiles of two batches follow one another, regardless of the scale of the respective graphs, we know the process is producing consistent results.

AccuBrew provides much more information than SG alone. AccuBrew recommends comparing batches on a regular schedule. Daily comparison of the current batch, against the gold standard batch helps brewers identify anomalies and react quickly to keep the batch on schedule.

For example, by regularly comparing batches brewers may notice the current batch is lagging the reference batch. If a decision is made to increase temperature or rouse the wort to accelerate fermentation, comparing batches the next day helps evaluate the effect produced by the change without manual testing.

The Clarity Profile, a unique feature of the AccuBrew system, is an extremely valuable tool for identifying the potential cause of an unexpected and sustained change in the fermentation profile. For example, a high flocculating yeast may flocculate prematurely, slowing or even stalling fermentation. Comparing Clarity Profiles will help brewers identify the danger before the batch stalls completely.

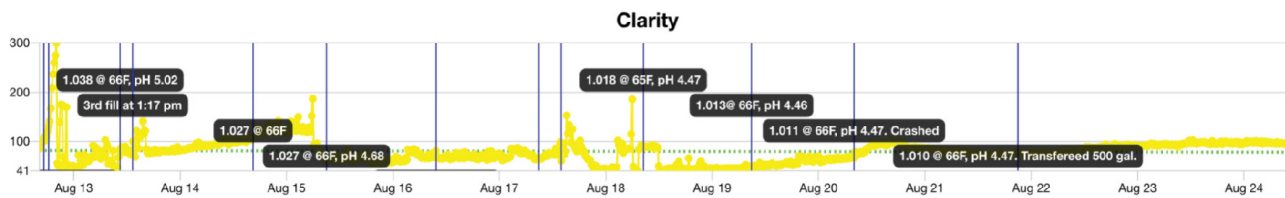

*The Clarity Profile helps brewers recognize the effects produced by additions or premature flocculation. Securely stored Brewers' Notes, create a permanent record.*

The indicators for this type of stall will be an unexpected, sudden, and sustained increase or decrease in clarity. Whether an increase or decrease is observed is dependent upon the position of the sensor in the vessel and the stratification of the solids in the fluid.

A decrease in clarity causes a peak on the Clarity Profile. If this peak cannot be attributed to an addition for example, and we are using a high flocculating yeast, it could indicate the yeast is flocculating prematurely and the batch is in danger of stalling.

Conversely, an otherwise unexplained and premature increase in clarity, appearing as a trough on the Clarity Profile when compared to the reference batch, may indicate the yeast is flocculating above or below the sensor.

In all cases it is important to add a detailed note to the current batch explaining the reason for a process adjustment, especially if the batch is a seasonal product made only

a couple of times a year. For example, by reviewing notes before brewing a new batch, a proactive decision can be made to start fermentation at a higher setpoint or set a reminder to increase the setpoint or rouse the wort to prevent a stall.

The hardest part of brewing beer is producing consistent results. Truly consistent results through all phases of fermentation are confirmed by regular comparison to reference batches. Once consistent results are achieved it becomes much easier to evaluate any adjustments to the process, such as small changes in temperature, the amount of yeast pitched, when additions are made, etc.

These are just a few of the reasons why monitoring SG on its own is not enough. The more dynamic nature of the Fermentation Activity and Clarity profiles allows brewers to see what is happening in the tank, even after the target gravity is hit. We look forward to learning how brewers use the AccuBrew system to improve their products.

# The Future Of AccuBrew

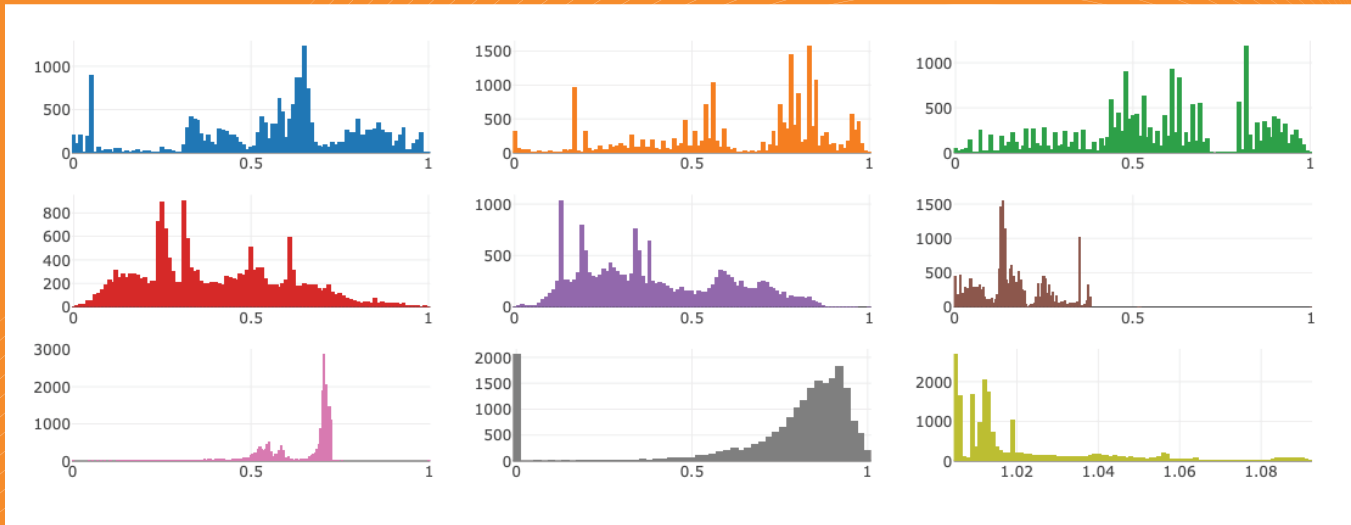

*These graphs represent the features the AccuBrew machine learning algorithm will use to transform the relative Fermentation Profile into a reliable Specific Gravity Profile.*

AccuBrew is always looking to the future. In addition to the current product designed for production breweries, we are developing an affordable sensor package for home brewers with all the analytical features of the production package.

The current sensor package also includes a temperature control signal that will one day be available as the input signal for glycol temperature controllers, freeing up a valuable port. We are also working to develop an API to allow integration of the AccuBrew sensor data with modern brewhouse control systems and brewery management software.

AccuBrew is always looking for partners who require continuous process monitoring and secure storage of remote sensor data. Contact Gulf Photonics to evaluate integrating your sensors into our IoT infrastructure. The AccuBrew user interface is readily adaptable to your needs.

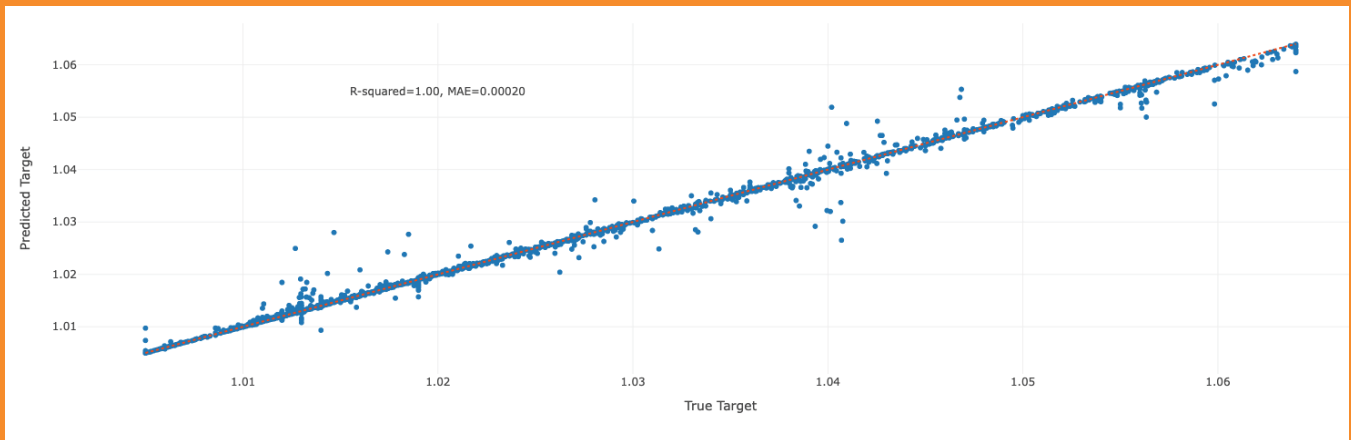

*An early plot of the data points generated by the AccuBrew machine learning algorithm begins to illustrate the linear relationship of the algorithm's Predicted Targets and the True Targets obtained from gravity tests in the lab.*

Additionally, as a manufacturer of custom fiber optic cables, Gulf Photonics is available to design and build custom fiber optic cable assemblies to fit the needs of a variety of industries, from medical to aerospace and beyond.

# Gulf Photonics Quality Policy

Gulf Photonics is committed to providing high quality products and services for the medical, photonics, spectroscopy, metrology, and research & development industries.

## We recognize that achieving this goal requires:

- Continuous improvement in what we do and how we do it: provide best in class products and service to our customers.
- A work environment where open and honest communication fosters teamwork and timely problem resolution.
- Meeting or exceeding all customer, statutory, and regulatory requirements.
- A commitment to comply with, maintain, and continuously improve the effectiveness of our Quality Management System.

## Quality Management System Level Quality Objectives:

- Show an improvement in maintaining the effectiveness of the Quality Management System.
- Show an improvement in product reliability.
- Show continuous improvement in our production processes by minimizing avoidable non-conformances.
- Implement, maintain, and comply with an ISO 13485 Quality Management System.
- Deliver every order on time.



# AccuBrew Privacy Policy: *Why A Subscription?*

## **AccuBrew believes, what's yours is yours!**

Accubrew is a subscription service because we respect your privacy and time. AccuBrew will never use invasive ads or collect, share, or sell personal information. Subscriptions cover the cost of server space, tech support, and continued development.

Because we respect your privacy and time and refuse to collect and sell personal information or clutter up your device with invasive ads, we needed a new solution. This led us to two unique ideas.

The first is pricing based not on hiding ads, but to encourage adding sensors. Buy one no contract, monthly subscription and get 60% off each additional subscription. By reducing the cost of additional subscriptions, the more sensors you use, the better your ROI.

The second innovation is the option to pause subscriptions on demand. If you need ten sensors to monitor and protect every batch but only six during your off-season, just pause four to reduce costs.

We hope honesty, innovative pricing, and pause on demand help make using and supporting AccuBrew affordable and painless.

**Monitor every batch, only pay for what you need, when you need it, and enjoy year-round peace of mind with AccuBrew!**



# Thank You!

We appreciate you taking the time to learn more about the AccuBrew Fermentation Monitoring System, which is proudly designed and assembled in the USA, using globally sourced components.

*Your customers compare every batch, now you can compare batches with precision.*

Cheers,  
The AccuBrew Crew



**PATRICK**  
"Biz Whiz"



**CRAIG**  
"The Beacon"



**CHRIS**  
"Beer Engineer"



**BRAD**  
"Wizard of Electrons"



**PARKER**  
"Roadie"

